

serie
range
FRV



Morello Forni®

Forno rotante elettrico ventilato
Rotating electric convection oven



- QR Code 1:
 - Forno elettrico a convezione con platea rotante
 - Doppio sistema di riscaldamento indipendente a temperatura differenziata di volta e platea
 - Gestione termostatica delle temperature con controllo indipendente della forza convettiva
 - Gestione percentuale della potenza elettrica alle resistenze
 - Sistema di gestione automatico, senza intervento continuo dell'operatore
 - Cupola e platea in materiale refrattario
 - Coibentazione termica super efficiente per diminuire le perdite di calore
 - Rotazione platea a velocità e direzione variabili, a regolazione manuale e controllo automatico
 - Tre programmi di cottura impostabili per automatizzare e semplificare il lavoro dell'operatore
 - Il sistema garantisce uniformità alla cottura
 - Riduzione tempi di cottura con aumento della produttività
 - Luce interna



- QR Code 2:
 - FRVs are electric rotating convection ovens
 - Dual temperature-based independent heating system for dome and bedplate
 - Thermostatic management with separate convective force control
 - Heating resistors electric power percent control
 - Automatic oven management, not requiring constant user intervention
 - Refractory dome and bedplate
 - Highly efficient thermal insulation to minimize heat losses

- Speed and direction variable bedplate rotation, with manual adjustment and automatic control
- Up to three baking programs can be set up to ease and automate operator's tasks
- The rotating system provides baking uniformity and shorter cooking times, increasing productivity
- Internal light



FRV 125 CM-V CRYSTAL GOLD

le finiture della linea / range finishes • **FRV**

FORNO ROTANTE / ROTATING OVEN

**CERTIFICAZIONI
CERTIFICATION**

costruiti e omologati
secondo le norme
*manufactured and certified
according to norms*



Mod./Ref.	Consumo massimo/ Consumption maximum	Mantenimento consumo/ Maintaining consumption	Capacità pizze Ø 30 cm./ Capacity pizzas Ø 30 cm.	Produzione oraria/ Productivity per hours
FRV100	15 KW	2,5 KW	6 pizze	90 pizze/h
FRV125	24 KW	5 KW	9 pizze	160 pizze/h

serie
range
FRV

Forno rotante
elettrico ventilato
*Rotating electric
convection oven*

FORNO ROTANTE / ROTATING OVEN

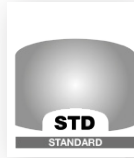
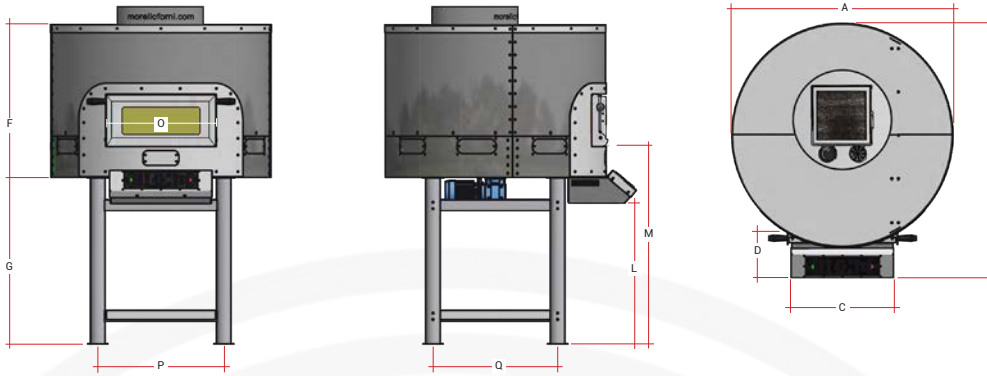

Mod./Ref.	A	B	C	D	F	G	L	M	O	P	Q	peso/weight (kg)
FRV100	120	147	56	33	97	90	72	112	56	70	70	650
FRV125	162	180	98	35	105	80	80	122	65	90	110	1550

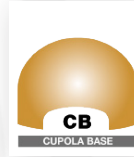
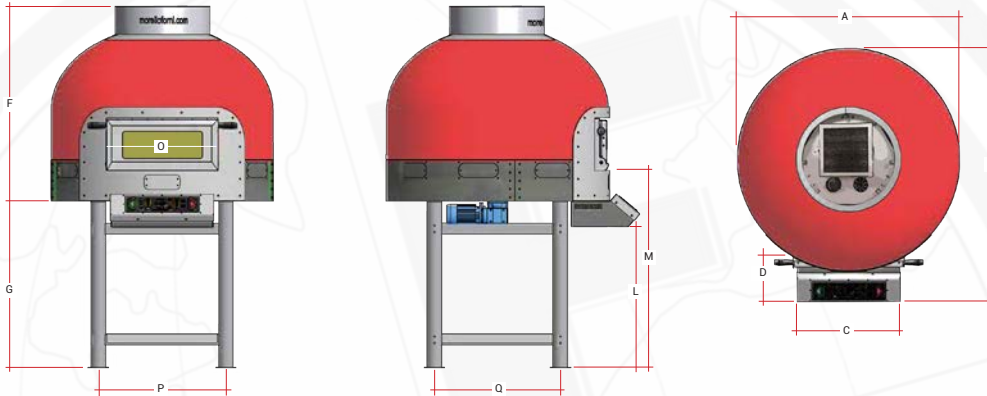

Mod./Ref.	A	B	C	D	F	G	L	M	O	P	Q	peso/weight (kg)
FRV100	120	147	56	33	105	90	72	112	56	70	70	650
FRV125	162	180	98	35	120	80	80	122	65	90	110	1850

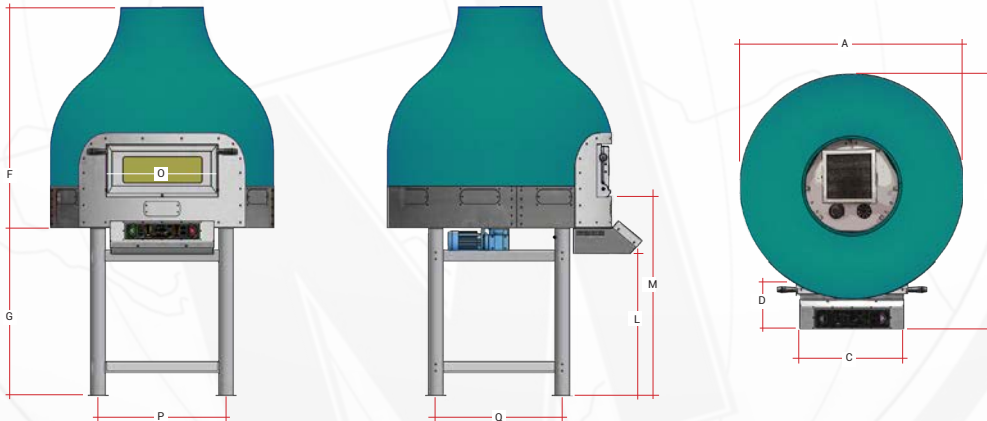

Mod./Ref.	A	B	C	D	F	G	L	M	O	P	Q	peso/weight (kg)
FRV100	120	147	56	33	110	90	72	112	56	70	70	650
FRV125	162	180	98	32	135	80	80	122	65	90	110	1900

alcune nostre finiture
some of our finishes



FRV 100 STANDARD

FRV 125 CB NERO MORELLO

FRV 100 CM-V CRYSTAL COPPER

MORELLO FORNI ITALIA Srl

Via B. Parodi, 35 - 16014
Ceranesi (Genova) - Italy
Tel. +39 010 7401194
Fax + 39 010 7492194
info@morelloforni.com

www.morelloforni.com



i nostri ricambi / our spare parts
parts.morelloforni.com