

2 BURNERS + GAS SOLID TOP ON GAS OVEN



- External paneling in stainless steel
- Work surface in AISI 304, 1.2 mm thick
- Height-adjustable work surface from 855 to 900 mm
- Extra-thick radiant plate with reinforcement for proper heat distribution, equipped with central cut-out
- Heating with high-power circular steel burner
- Reaches a temperature of 500°C at the centre of the plate and 200°C near the edges
- Complete with pilot burner and safety thermocouple, gas supply controlled by safety valve
- Plate dimensions 700 x 500 mm
- Black enamelled cast iron grids; acid, alkaline and flame resistant.
- Burners with power 1 x 4 kW and 1 x 8 kW
- Oven base in steel
- Standard gas oven, 8 kW power
- Thermostat valve for temperature regulation between 100°C and 300°C
- Stabilized flame burner complete with pilot light, safety thermocouple and piezoelectric ignitor
- Cooking chamber dimensions 693 x 300H x 580 mm GN 2/1
- Steel inner door with seal
- Ergonomic control panel with controls tilted toward the operator
- Height-adjustable stainless steel feet

TECHNICAL SPECIFICATIONS

Dimensions (mm)	1200x700x900
Volume (m ³)	2,30
Weight (kg)	170

GAS CONNECTION

kW	32
UNI ISO 7/1 R 1/2"	
Cold water inlet	

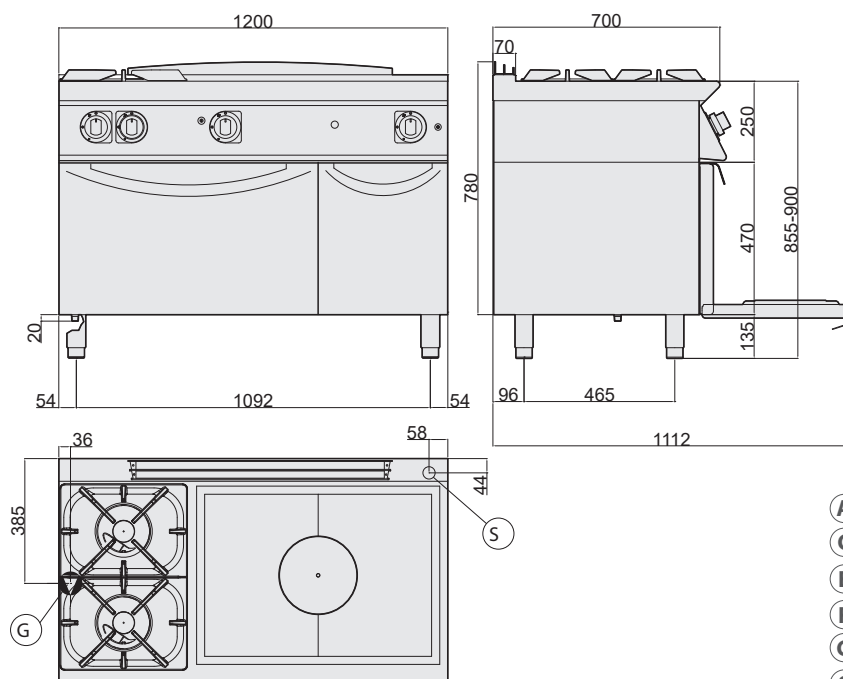

- Ⓐ water fill
- Ⓒ hot water fill
- Ⓔ electrical input
- Ⓕ cold water fill
- Ⓖ gas inlet
- Ⓗ water drain