

AUTOMATIC TILTING ELECTRIC BRATT PAN - BOTTOM IN DUPLEX 2304 - 120 L



- External paneling in stainless steel
- Work surface in AISI 304, 2 mm thick
- Height-adjustable work surface from 855 to 900 mm
- Tilting bratt pan with cooking tank and electric tilting
- Stainless steel tank with rounded corners for thorough cleaning
- Bottom in DUPLEX 2304, 10 mm thick
- Tank water filling via valve and filling spout
- Double skinned lid with rear drainer to transfer condensate into the tank
- Hinges in AISI 304 satin steel with counter-balance lid and front handle for lifting
- Heating with Incoloy heating elements positioned under the tank
- Temperature regulation via thermostat between 50°C and 300°C
- Equipped with safety thermostat
- Cooktop 1126 x 595 mm, capacity 120 L
- Heating interruption via micro-switch if the tank is lifted
- Indicator lights to monitor the correct operation of the appliance
- Height-adjustable stainless steel feet

TECHNICAL SPECIFICATIONS

Dimensions (mm)	1200x900x900
Volume (m ³)	2,10
Weight (kg)	200

ELECTRICAL CONNECTION

kW	19
Power supply	VAC 400/3N 50/60Hz
Cold water inlet	1/2"

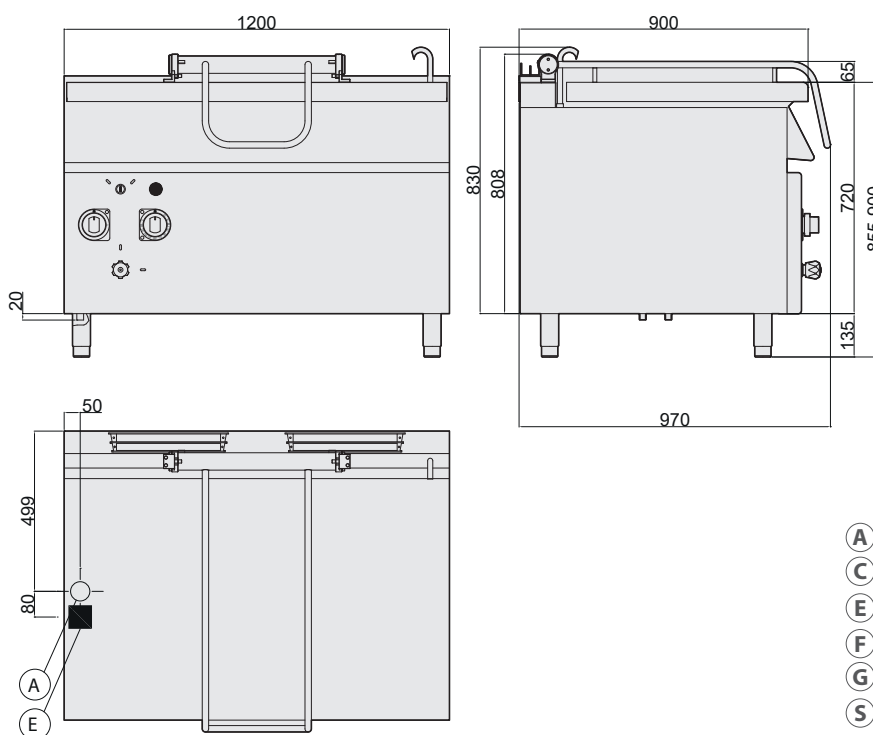

- Ⓐ water fill
- Ⓒ hot water fill
- Ⓔ electrical input
- Ⓕ cold water fill
- Ⓖ gas inlet
- Ⓢ water drain

